

Miller® MiniLite™ Fall Limiter Cab Mount Bracket

**The new Miller®
MiniLite™ Fall Limiter
Cab Mount Bracket is
designed to fit a wide
range of lift trucks.**

Offers:

- Increased overhead clearance in lift truck cab
- Quick & easy installation
- Non-protruding mount
- Heavy-duty steel construction

Mounted on the overhead guard stringer, the bracket extends less than 2 inches into the lift truck cab. The bracket allows for easy attachment and removal of a basic MiniLite Retractable unit.

Available in a kit with the Miller MiniLite Fall Limiter (FL11-0) or the bracket can be purchased separately.

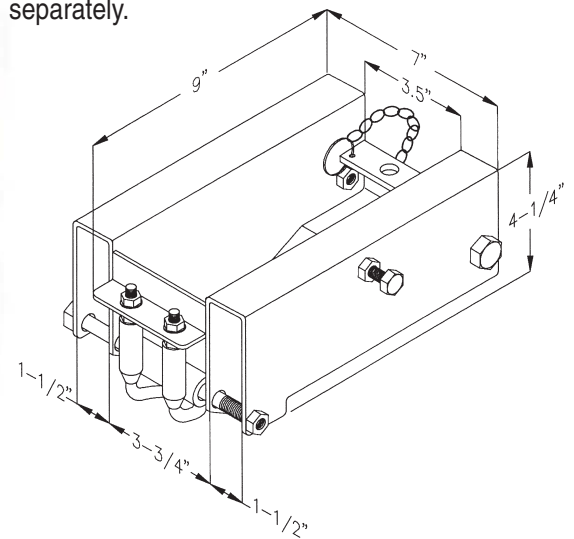

Model No. Product Description

FL11CMK	Lift Truck Kit [w/MiniLite (FL11-0) and bracket]
FL11CM	Bracket Only (Accommodates MiniLite model FL11-0)
FL11-0	MiniLite Fall Limiter w/swivel snap hook

MILLER®
by SPERIAN

**Accommodates lift trucks
manufactured by . . .**

Atlet, Clark, Cat, Crown, Hyster, Mitsubishi,
Raymond, Steinbock and Yale



Other Innovative Fall Protection Products

MiniLite™ Fall Limiter

Quick-Activating Locking Mechanism

Arrests a free fall WITHIN INCHES.

Compact Design

Lightweight and easy to handle. 11 ft. of webbing capacity.

Corrosion-Resistant Interior, Frame and Components

Stainless steel interior, frame and components. Corrosion-resistant internal parts.

High-Impact Protective Outer Cover

Durable construction protects internal components and webbing from harsh environments.

Prominent Reflective Labels

High visibility provides extra security for evening work activities.

Trilingual Instructions

Assists with product use training and inspection.

Visual Load Indicator

Warns that a product has seen fall arrest forces. Aids with inspection.

Model No.	Description	Length	Weight
FL11	MiniLite without an Anchorage Connector	11 ft. working capacity	2.5 lbs. (1.1 kg)

Miller® Warehouse Harness

Unique D-ring web extension prevents swing interference — increasing safety and productivity

The unique Miller Warehouse Picker's Harness increases productivity and safety by preventing swing interference of the back D-ring and attached snap hook during warehouse operations. This uniquely-designed harness offers a D-ring web extension tacked to a back strap, keeping the components further away from the body so as not to interfere with the worker.

In the event of a fall, the web extension detaches from the back strap allowing the D-ring to move into position to ensure that the worker remains upright.

Miller harnesses meet all applicable OSHA, ANSI, and CSA requirements, including ANSI Z359.1.



Applicable OSHA/ANSI/CSA/CE Standards

- OSHA 1926.502
- OSHA 1910.66 Appendix C
- ANSI Z359.1
- ANSI A10.14
- CSA Z259.2
- CE EN360



Model No.	Product Description
Model #E850-2 (shown)	Specially-formulated stretchable DuraFlex webbing for greater mobility and comfort with less fatigue
Model #850-2	Same as Model #E850-2, except with conventional nylon webbing

This equipment should only be used after reading the manufacturer's instructions. Failure to follow instructions could result in serious injury or fatality.



▶ Ask the Expert ... Ask Miller.

800/873-5242
or 814/432-2118

Fax 800/892-4078
or Fax 814/432-2415

www.millerfallprotection.com



For more information or to place an order, please contact your Miller® distributor:

LCMB/0102/15M/MP